

## PMS POWER METERING PRECISION SHUNTS



These components have E-beam welded manganese-copper alloy elements giving high strength, stability and reliability. Low thermal EMF and TCR. Small size and minimal power loss. Minimal heat generation and surface temperature due to small total resistance. Proprietary processing technique allows very low resistance values. Ideally suited for KWh meters and sampling sensor shunts. These units are also suitable for custom design.

### SPECIFICATIONS

Model	Power Rating	Resistance	Tolerance
PMS	3W	100 $\mu$ R-500 $\mu$ R	+ -1%, + -5%, + -10%

### CHARACTERISTICS

Values in [ ] mean change in ohmic value after test

Temperature Range	-55C-125C
Temperature Coefficient	$\leq$ +50ppm/C
Internal Heat Resistance	<10K/W
Load Life	Deviation <0.5% after 2000hrs. @80C

### DIMENSIONS

Resistance Value	Component Thickness	Rated Current
$\leq$ 100 $\mu$ R	2.0mm	100A
120 $\mu$ R	1.5mm	80A
150 $\mu$ R	1.5mm	60A
200 $\mu$ R	1.2mm	60A
250 $\mu$ R	1.2mm	40A
300 $\mu$ R	1.0mm	40A
350 $\mu$ R	1.0mm	30A
$\geq$ 500 $\mu$ R	1.0mm	30A

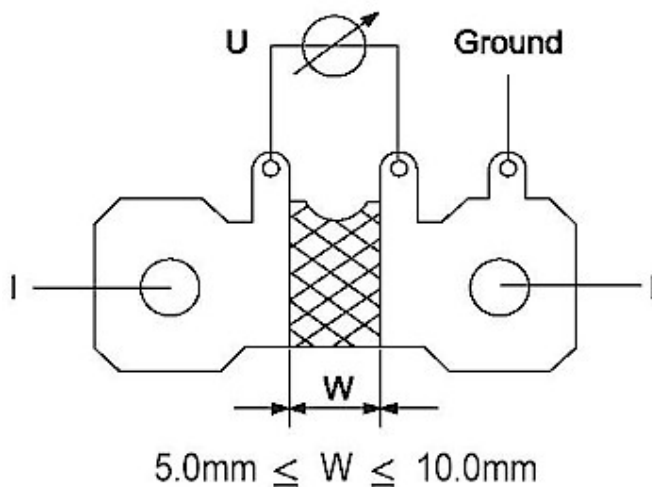

### DERATING CURVE

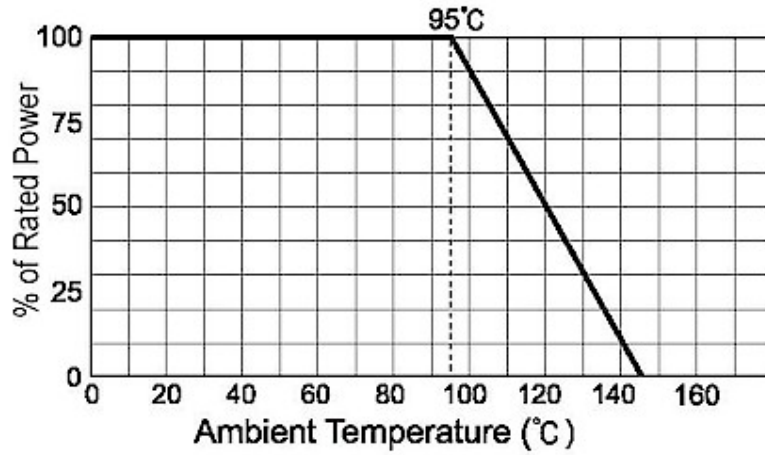

### ORDERING PROCEDURE EXAMPLE

