

## RQL CERAMIC ENCASED WIRE WOUND RESISTORS

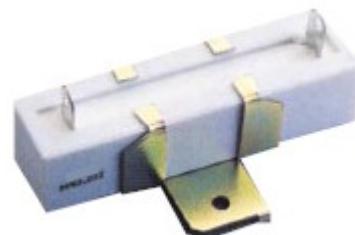

### Features

- Ohmic values from 0.3 to 100K
- Rated power from 10 to 40W
- Economical solution



### GENERAL SPECIFICATIONS AND DIMENSIONS

Model	Wattage Rating	Resistance Range( $\Omega$ )			Resistance Tolerance
		Glass Fiber Core (GC)	Ceramic Core (CC)	Metal Oxide Film (MO)	
RQL 10	10W	0.5-1.5K	0.3-10K	10-75K	R $\leq$ 1 $\Omega$ : $\pm$ 10% R > 1 $\Omega$ : $\pm$ 5%
RQL 15	15W	1.0-1.5K	0.5-12K	10-100K	
RQL 20	20W	1.0-2.0K	0.5-15K	10-100K	
RQL 25	25W	1.0-2.0K	-	-	
RQL 30	30W	1.5-4.0K	-	-	
RQL 40	40W	2.0-5.0K	-	-	

### CHARACTERISTICS

Values in [ ] mean change in  $\Omega$  after test

Temperature Range		-25C-155C
Insulation Resistance		DC500V, 20M $\Omega$ Minimum
Dielectric Withstanding Voltage		AC 1500V for 1minute
Temp. Coefficient		Less than 1 $\Omega$ : 490-1300ppm/C. More than 1 $\Omega$ : 490ppm/C
Short Time Overload	$\Delta R \pm [2\% + 0.05\Omega]$	10 Times rated power for 5 sec.
Moisture Resistance	$\Delta R \pm [3\% + 0.05\Omega]$	DC 100V, 40C 95% RH, 500h
Thermal Shock	$\Delta R \pm [2\% + 0.05\Omega]$	Power Rating 30 min., -25C 15min.
Moisture Load Life	$\Delta R \pm [3\% + 0.05\Omega]$	40 $\square$ 95% RH, 10% Power Rating 90min.-ON
Load Life	$\Delta R \pm [5\% + 0.05\Omega]$	Power Rating 90min.-ON, 30min.-OFF
Solderability		75% Coverage minimum

Note: Applied voltage = AC RMS voltage

### ORDERING PROCEDURE EXAMPLE

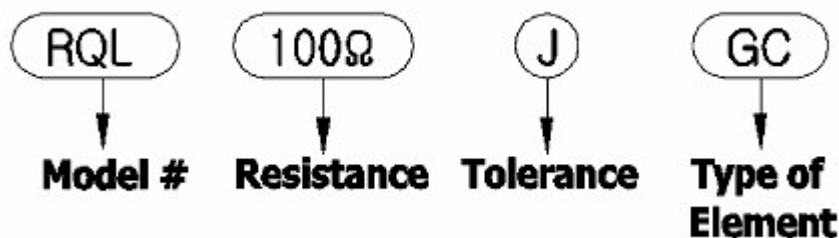

**DERATING CURVE**

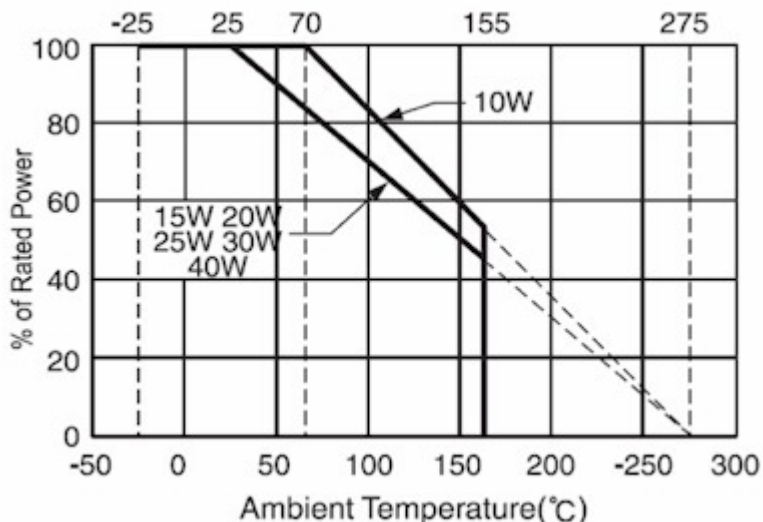

**SURFACE TEMPERATURE INCREASE VERSUS POWER LOAD**

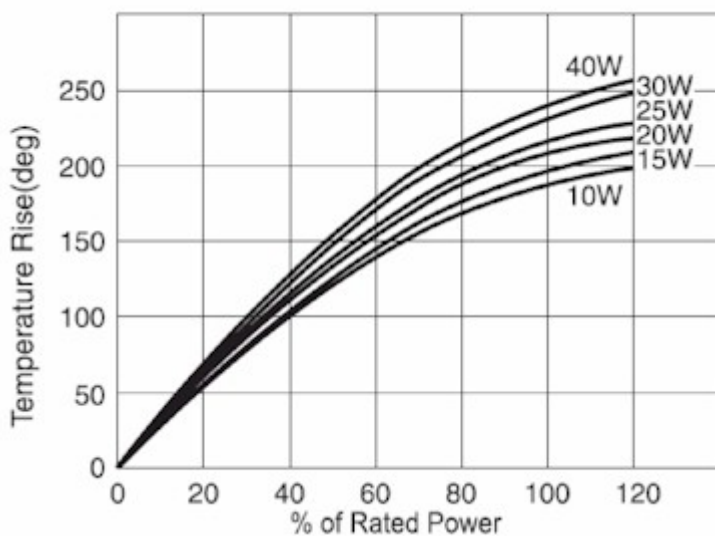

**RQL (g) DIMENSIONS**

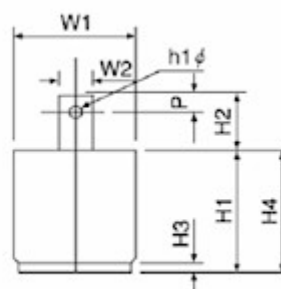
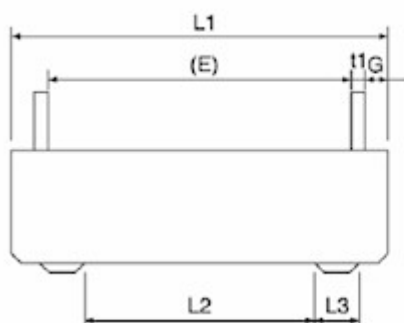

Power Rating(W)	Dimensions(mm)													
	L1	L2	L3	W1	W2	H1	H2	H3	H4	P1	(E)	G1	t1	h1Φ
10	48±1.5	25±1	4.5	9.5±1.0	5	9.5±1.0	6+1.5	0.8	16.5+1.5,-1.0	2.5	36.0-2	5.5+2,-1	0.4	2
15	48±1.5	25±1	7	12.5±1.2	6	12.5±1.2	7.5+2	1.0	21+2.0,-1.0	3	34.0-2	6.5+2,-1	0.5	2.5
20	63.5±2	25±1	7	12.5±1.2	6	12.5±1.2	7.5+2	1.0	21+2.0,-1.0	3	48.0-3	6.5+2,-1	0.5	2.5
25	63.5±2	25±	8	16±1.2	7.5	16±1.2	12+2	1.0	29+2.5,-1.5	3.5	46.5-3	8-2.5,-1	0.5	3
30	75±2.5	40±1.2	10	19±1.5	7.5	19±1.5	10+2	1.0	30+2.5,-1.5	3.5	56.0-4	9+3,-1	0.5	3
40	90±2.5	40±1.2	10	19±1.5	7.5	19±1.5	10+2	1.0	30+2.5,-1.5	3.5	71.0-4	9+3,-1	0.5	3

**■ RQL (t) DIMENSIONS**

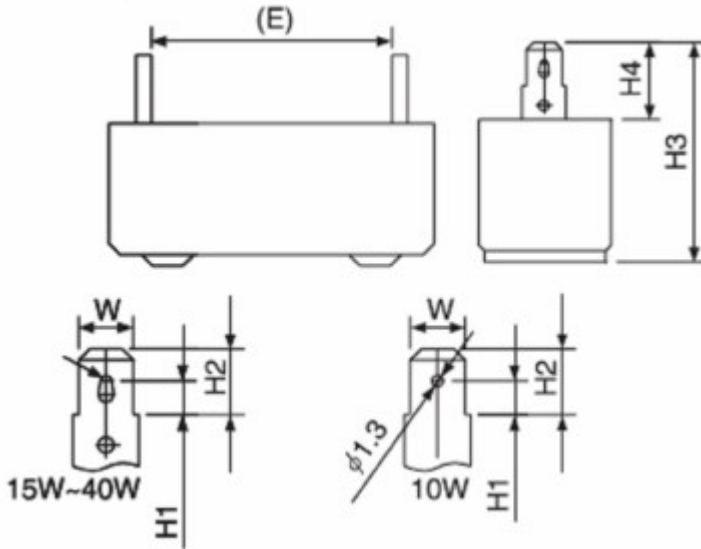

Power Rating(W)	Dimensions(mm)							
	H1	H2	H3	H4	W	R	t	(E)
10	3.2±0.1	6.35±0.1	20.8+2,-1	10+1.5	4.75±0.1	Φ13	0.5±0.2	36
15	3.2±0.1	6.35±0.1	25.5+2,-1	12+2	4.75±0.1	0.65±0.2	0.5±0.2	34
20	3.2±0.1	6.35±0.1	25.5+2,-1	12+2	4.75±0.1	0.65±0.2	0.5±0.2	48.0
30	4±0.1	7.95±0.1	35.5+2,-1	15.5+2	6.35±0.1	0.825±0.2	0.8±0.2	55.5
40	4±0.1	7.95±0.1	35.5+2,-1	15.0+2	6.35±0.1	0.825±0.2	0.8±0.2	70.5

**■ RQL (b, s) DIMENSIONS**

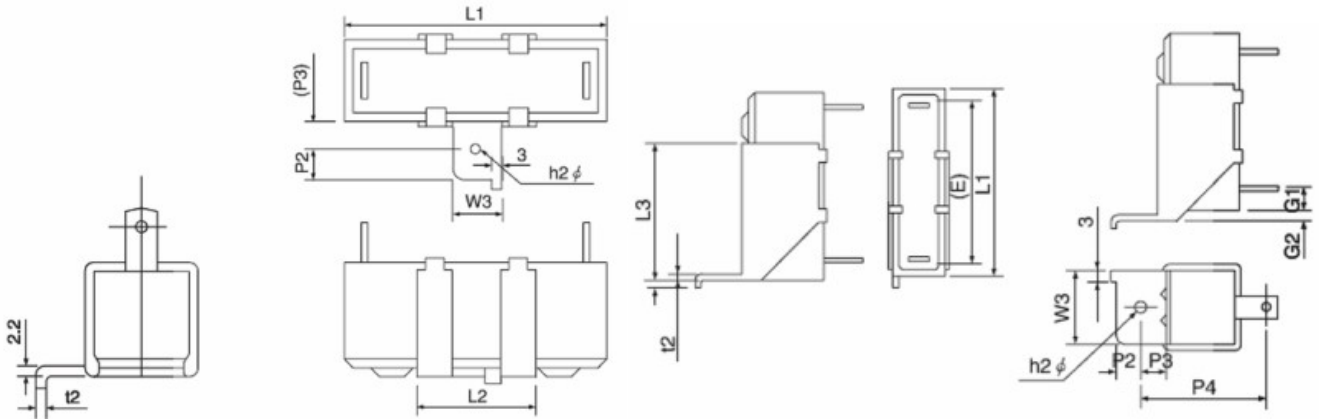

Power Rating(W)		Dimensions(mm)										
		L1	L2	L3	W3	P2	(P3)	P4	G1	G2	t2	h2Φ
10	b	48±1.5	24	-	12±0.2	6	8	-	5.5+2,-1	-	0.6	4
15	b	48±1.5	24	-	12±0.2	6	8	-	6.5+2,-1	-	0.8	4
	s	56±2	-	43	-	-	-	28-1~-2.5		8±2	0.6	
20	b	63.5±2	24	-	12±0.2	6	8	-	6.5+2,-1	-	0.8	4
	s		-	43				-		28-1~+2.5	-	
25	b	63.5±2	24	-	12±0.2	6	10	-	8+2.5,-1	-	0.8	4.2
30	b	78±2.5	39	-	18±0.2	8	10	-	9+3,-1	-	0.8	4.2
	s	82.5±2.5	-	-	-	-	-	39-1.5~+3		7.5±2	0.8	
40	b	90±2.5	39	-	18±0.2	8	10	-	9+3,-1	-	0.8	4.2
	s		-	64				-		39-1.5~+3	-	